

**SOLID STATE
SCINTILLATION PROBE
MODELS SC3840, SC5050**

OPERATION MANUAL



CORPORATE HEADQUARTER

CTT,
23, rue du Loess, BP 20,
F-67037 STRASBOURG-CEDEX 2
Tel. : +33 (0)3 88 26 81 30,
Fax : + 33 (0)3 88 28 45 48
E-mail : info@eurorad.com
Web : www.eurorad.com

COMMERCIAL OFFICE

24, rue du Pont
F-94430 CHENNEVIERES SUR MARNE
Tel : +33 (0)1 56 86 11 49
Fax : +33 (0)1 56 86 11 50
E-mail : info@eurorad.com
Web : www.eurorad.com

TABLE OF CONTENTS

INTRODUCTION.....	3
SOLID STATE GAMMA RAY PROBES USING A SILICON PHOTODETECTOR COUPLED TO A CsI(Tl) SCINTILLATOR (SCINTILLATION PROBE WORKING WITHOUT PHOTOMULTIPLIER TUBE).....	3
TYPICAL PERFORMANCE OF SILICON AND CSI(TL) SCINTILLATORS.....	4
MAIN CHARACTERISTICS OF THE PREAMPLIFIER.....	4
CHARGE SENSITIVE PREAMPLIFIER.....	4
PROBE CONNECTOR.....	5
ELECTRICAL POWER REQUIRED.....	5
CABLE.....	5
CONNECTION.....	6
CONNECTION DIAGRAMM.....	6
MECHANICAL CHARACTERISTICS.....	7
MAIN CHARACTERISTICS OF CSI (TL) SCINTILLATORS.....	8
CSI SCINTILLATOR.....	9
LINEAR ATTENUATION COEFFICIENTS.....	9

INTRODUCTION

SOLID STATE GAMMA RAY PROBES USING A SILICON PHOTODETECTOR COUPLED TO A CSI(TL) SCINTILLATOR (SCINTILLATION PROBE WORKING WITHOUT PHOTOMULTIPLIER TUBE)

Scintillation's probes have been over decades the most popular gamma ray detectors; they combine a scintillator and a photomultiplier tube (PMT). In such a set-up the light generated by the incoming radiation in the scintillator (generated by a complicated molecular physics mechanism) is transmitted to a photocathode in which electrons are generated, the later are directed to a series of dynodes (10 to 15) where the electrons are multiplied.

This proven arrangement has several advantages but suffers from a series of drawbacks, in particular: the unstability of the gain of the PMT tube giving rise to pulse shifts, a poor quantum efficiency to output signal and the necessity of larger housings and high voltage power supplies.

SILICON TECHNOLOGY PROGRESS has made possible to replace advantageously the PMT by a SEMICONDUCTOR PHOTODIODE working with 20 to 40 volts with leakage currents in the range of 1 nA (instead of mA in a PMT). These diodes are very compact and insensitive to magnetic fields. Furthermore, no internal amplification is used in the silicon diode.

To match the maximum quantum yield of the silicon photodetector, the best suited scintillator is CsI(Tl), rather than NaI(Tl). This scintillator offers practically the same photon yield per energy loss and furthermore, it is mechanically stable and non hygroscopic like NaI(Tl), furthermore, it's radiation length is shorter than NaI(Tl) i.e. 1.85 cm for CsI against 2.59 for NaI. For a CsI scintillator the quantum efficiency is 69% in Silicon, against 8% in bialkali photocathodes.

the table below (table I) shows the main characteristics of the most popular scintillators.

From the above quoted numbers it is clear that the attainable energy resolution in the SILICON + CsI(Tl) set-ups will NOT be limited by the statistical fluctuations in the number of photoelectrons. The ELECTRONIC NOISE in the DIODE and ENTRANCE STAGE of the PREAMPLIFIER are the determinant factors for the achievable energy resolution.

These noise parameters limit the lowest energy threshold to be detected above the noise level at R.T. operation about 80 to 100 keV.

Above 500 to 600 keV gamma ray energies the performance of the new set-up are BETTER THAN THOSE OF PMT ASSEMBLIES for ENERGY RESOLUTION. The EFFICIENCY of such a set-up is determined by the size of the scintillator and is, therefore, independent of the light measurement procedure.

TYPICAL PERFORMANCE OF SILICON AND CSI(TL) SCINTILLATORS

TABLE I

TYPE	CsI(TL) SCINTILLATOR SIZE (MM)	TYPICAL ENERGY RESOLUTION AT 661 keV (137 Cs)
SC3840	Ø = 38, L = 40	66 keV (10%)
SC5050	Ø = 50, L = 50	100 keV (15%)
OTHER SIZE AVAILABLE ON REQUEST UP TO Ø50		

MAIN CHARACTERISTICS OF THE PREAMPLIFIER

CHARGE SENSITIVE PREAMPLIFIER

Energy resolution at 100 pf	3.6 keV FWHM (Si)
Energy resolution at 0 pf	1.3 keV FWHM (Si)
Sensitivity	440 mV/MeV (Si)
C/R feedback	1 pf/1000 Mo
Power requirement	+12V, 11 mA; - 12V, 6 mA
Output polarity	Negative

PROBE CONNECTOR

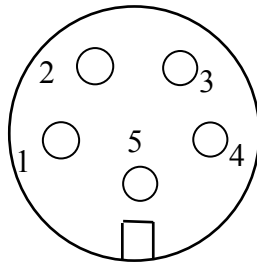

External view

CONNECTOR : Female LEMO

- 1 : - 12V
- 2 : +12V
- 3 : OUT
- 4 : NC
- 5 : GND

ELECTRICAL POWER REQUIRED

DB9 CONNECTOR

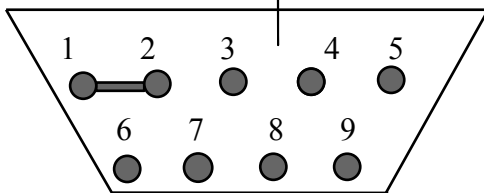

- 1-2 : GND
- 3 : NC
- 4 : + 12V
- 5-6-7-8 : NC
- 9 : - 12V

Output : Standard BNC

Power supply of the whole system through a standard connector to a NIM module amplifier (NIM standard).

Works with all major set-ups on the market except TENNELEC.

CABLE

Standard length 2 m
 Maximum length 25 m

CONNECTION

1. Connect the Amphenol DB9 to a NIM standard Rack.
2. Connect the BNC (output preamplifier) to the gaussian or triangular amplifier's input.
3. Connect the amplifier output to an MCA.

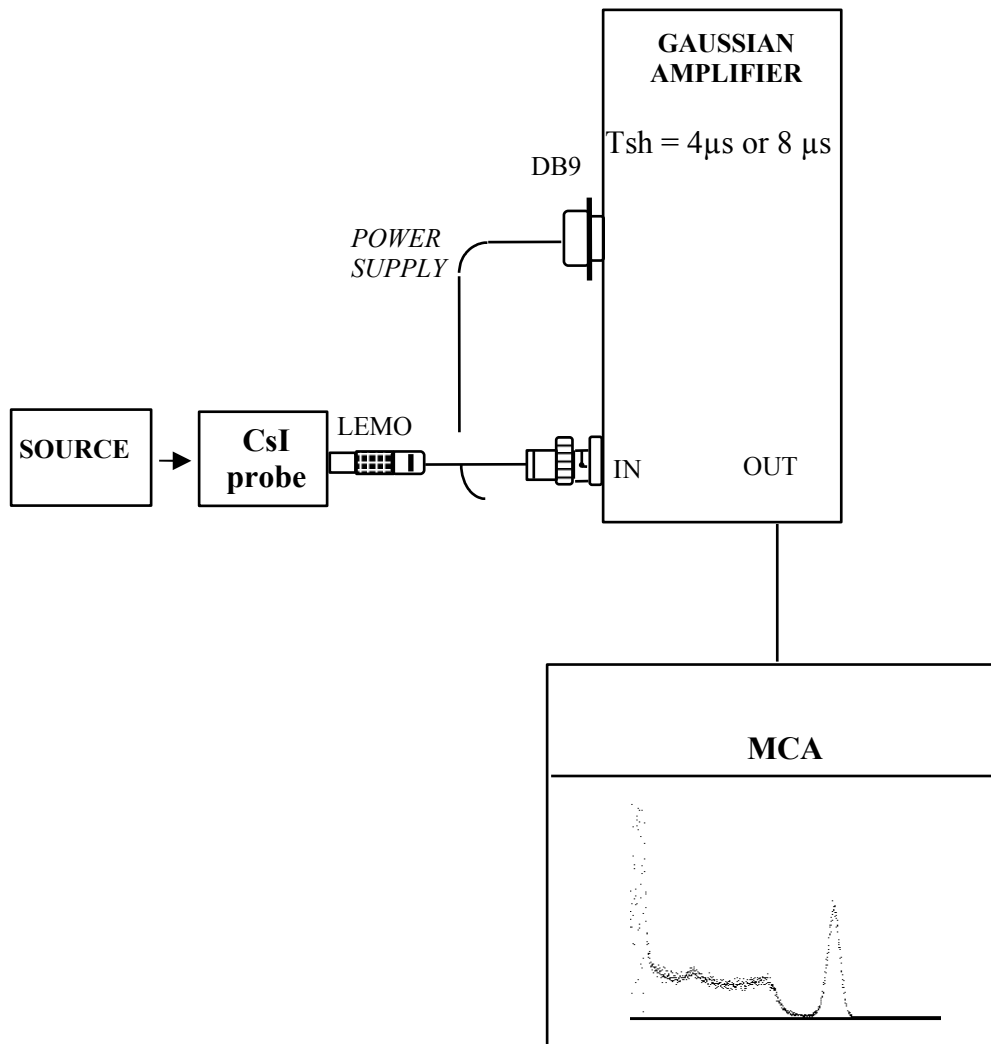
CONNECTION DIAGRAMM

MECHANICAL CHARACTERISTICS

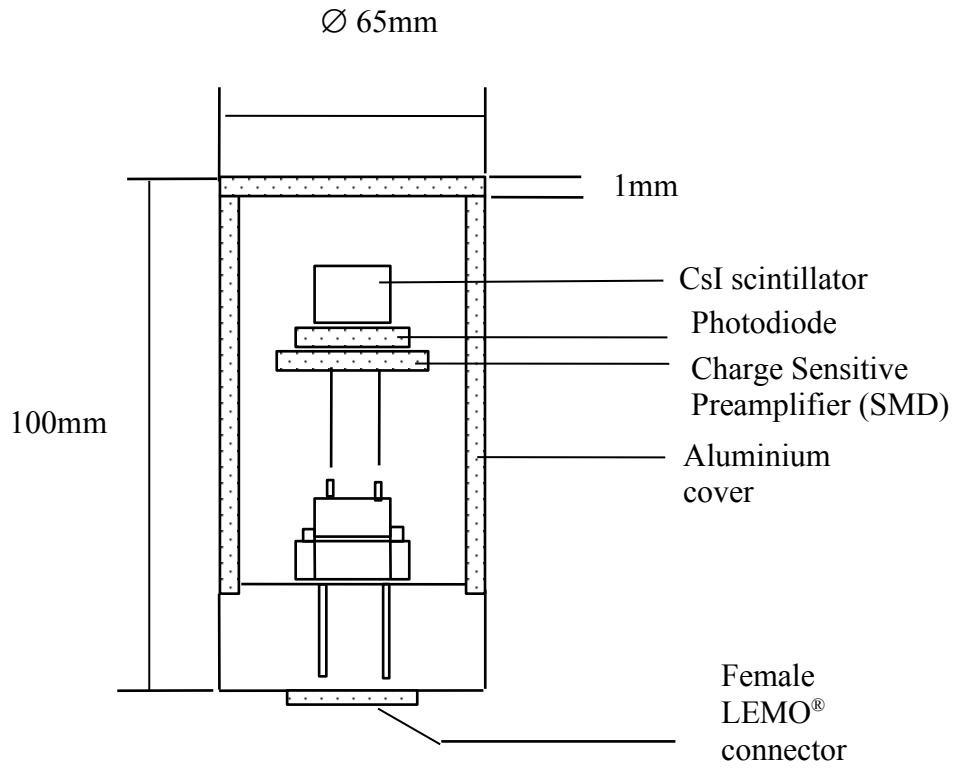

MAIN CHARACTERISTICS OF CsI (TI) SCINTILLATORS

- Density	4.41 g/cm ³
- Hygroscopy	slightly
- Solubility	85 g/100g H ₂ O
- Hardness	2 Mohs
- Melting temperature	621 °C
- Radiation length X ₀	1.86 cm
- Moliere radius	3.8 cm
- Interaction length	36.4 cm
- (dE / dx) at minimum	5.6 MeV/cm
- Maximum emission	550 nm
- Refractive index	1.8
- Ligth efficiency L	45% (S11)
- Photons efficiency	~ 4.10 ⁴ N/MeV
- ΔL / ΔT at 20 °C	-0.6 %/°C
- Time constant	~ 900 ns
- Δt / ΔT at 20 °C	-2 ns/°C
- After glowing	< 4.5% after 3 ms
- Radiation damage threshold	~ 10 ² Rads

CsI SCINTILLATOR LINEAR ATTENUATION COEFFICIENTS

CsI scintillator linear attenuation coefficients

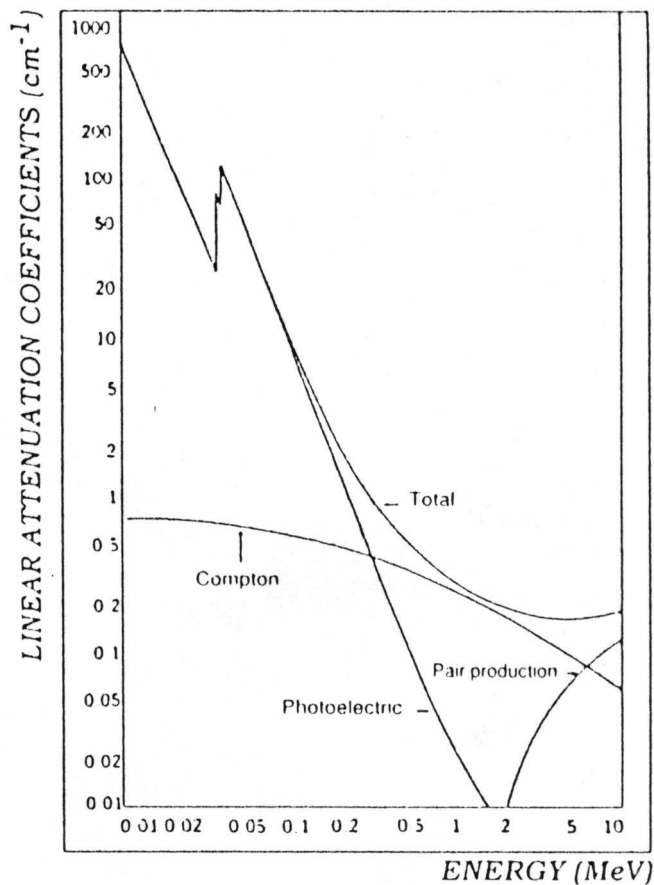

Specific masse = 4510 kg/m³
 Atomic number = $Z(I) = 53$
 $= Z(Cs) = 55$

Electron binding energies :
 K-edge (I) = 33.17 keV
 K-edge (Cs) = 35.98 keV
 L1-edge (Cs) = 5.72 keV
 L11-edge (Cs) = 5.36 keV
 L111-edge (Cs) = 5.01 keV

Average K X-ray energy (Cs) = 31.6 keV