

COMPACT PULSE PROCESSOR
for highresolution spectroscopy with
Cadmium Telluride detectors

CHARGE LOSS CORRECTOR
MODEL CPP II
MAINS POWERED 110V

OPERATION MANUAL



CORPORATE HEADQUARTER

CTT,
23, rue du Loess, BP 20,
F-67037 STRASBOURG-CEDEX 2
Tel. : +33 (0)3 88 26 81 30,
Fax : + 33 (0)3 88 28 45 48
E-mail : info@eurorad.com
Web : www.eurorad.com

COMMERCIAL OFFICE

24, rue du Pont
F-94430 CHENNEVIERES SUR MARNE
Tel : +33 (0)1 56 86 11 49
Fax : +33 (0)1 56 86 11 50
E-mail : info@eurorad.com
Web : www.eurorad.com

TABLE OF CONTENTS

DESCRIPTION.....	3
SPECIFICATIONS.....	5
1. PERFORMANCE.....	5
2. CONTROLS.....	5
3. INPUT.....	6
4. OUTPUTS.....	6
5. ELECTRICAL AND MECHANICAL.....	6
INSTALLATION.....	6
1. CONNECTION TO POWER.....	6
2. CONNECTION TO PREAMPLIFIER.....	6
3. LINEAR OUTPUT CONNECTION.....	7
THEORY OF OPERATION.....	7
CIRCUIT DESCRIPTION.....	9
HOW TO USE YOUR CPP II.....	11
1. INSTALLATION.....	11
2. TEST WITH A RADIATION SOURCE.....	12
HOW TO OBTAIN BETTER PERFORMANCES.....	19

DESCRIPTION

The EURORAD Charge Loss Corrector Model CPP is intended for spectrometric applications of planar CdTe and HgI₂ detectors. To improve energy resolution and photopeak efficiency in this device the functions of a normal spectroscopy amplifier are combined with a special designed electronic pulse processing unit. The Model CPP can operate with pure pulse shape discrimination or in a combined mode of pulse preselection and the newly developed charge loss compensation. Time variant pulse shaping ensures short amplifier deadtime and increases the system throughput at high counting rates.

There are two main factors which degrade the energy resolution of planar CdTe and HgI₂ detectors. The first one, the ballistic deficit is caused by large variations of charge collection time. It is overcome with an adapted timevariant pulse shaping method.

Figure 1:

The combination of ¹³⁷Cs spectra measured with selection (filled) and correction (solid line) normalised for same initial spectrum (dotted line) illustrates the gain of photopeak efficiency using the correction method.

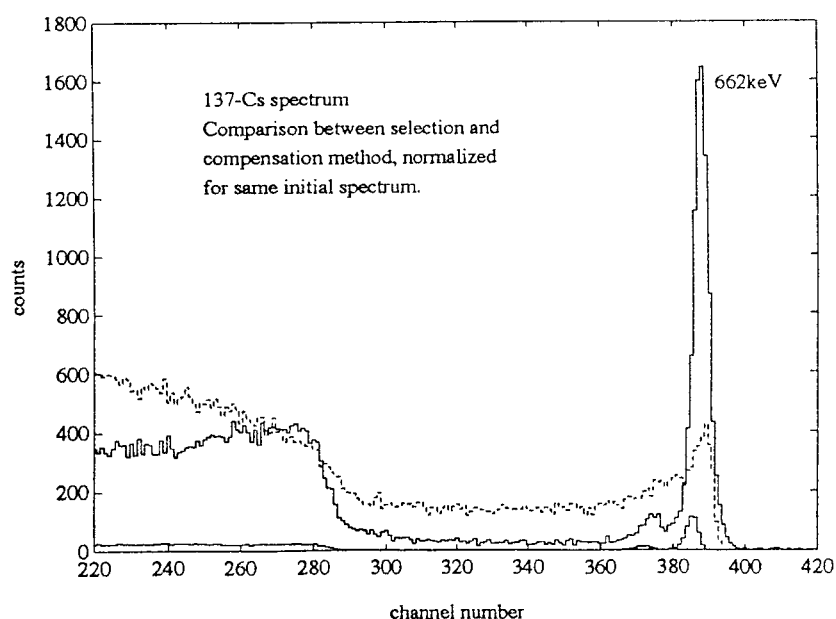

The second one, trapping and recombination in the bulk of the detector, is compensated using a method published by Richter and Siffert.¹

¹ Richter M., Siffert P., High resolution spectrometry with CdTe detector systems, 7th Internat. Workshop on Room Temperature X- and Gamma- Ray Detectors, September 23-28, 1991, Ravello - Italy.

Resolution and full energy peak efficiency of compound semiconductor gamma radiation detectors have been limited up to now by charge losses due to recombination of a more or less significant fraction of the photogenerated carriers. The resulting loss in pulse amplitude gives rise to low energy tailing of the photopeak. To enhance energy resolution pulse shape discrimination methods selected only signals that had been generated under optimum conditions. But the price for the improvement of energy resolution was an appreciable loss of detection efficiency.

A correlation between the fractional energy loss and the charge collection time has recently been discovered. Furthermore, this relationship is largely independent of the photon energy and is a constant property of the detector.

Figures 2 + 3:

Peak at an energy of 662 keV of a ¹³⁷Cs spectrum measured with pure pulse selection. The resolution is about 6 keV. This spectrum is the same as the filled one of Figure 1.

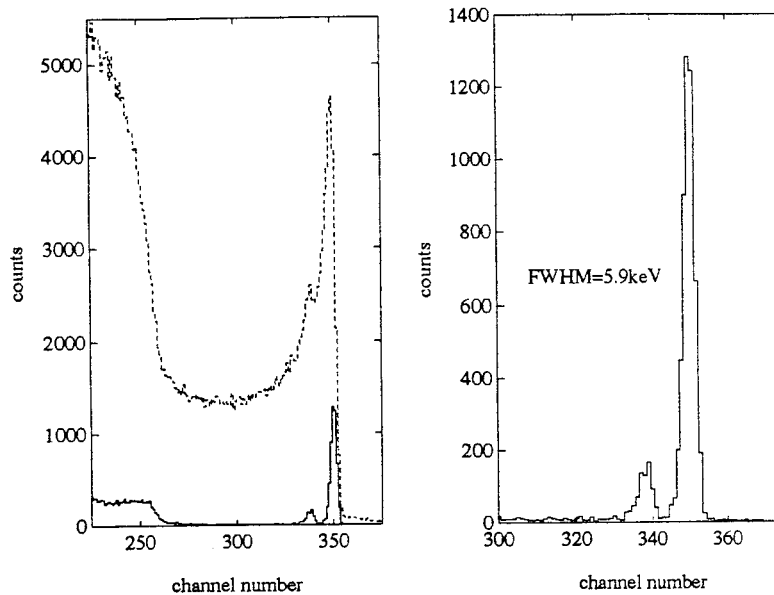

This discovery is used in the CPP. It corrects each pulse coming from a planar CdTe or HgI₂ spectrometer by an amount exactly equivalent to the charge lost by recombination. Thus pulses in the low energy tail are transferred into the photopeak. This results in better energy resolution, peak-Compton and peak-valley ratios in a gain of photopeak efficiency.

The performance of the Model CPP is illustrated in Figure 1. A spectrum measured with a small risetime selection window with disabled compensation (filled) is compared with another recorded using the preselection-compensation mode of the Model CPP with a much larger risetime window (solidline). The spectra were measured with the same measuring geometry and are normalised for the integral counts over the entire spectrum (dotted line). The gain of height of the photopeak is about ten.

If you deal with high radiation source activities or the measuring time doesn't play any role, you can profit from the slightly better energy resolution of the pure selection mode. Figures 2 + 3 show the filled spectrum of Figure 1 in another scale.

SPECIFICATIONS

1. PERFORMANCE

- GAIN RANGE: Continuously adjustable from X25 through X1500.
- PULSE SHAPING: Gated Integrator.
- INTEGRAL NONLINEARITY: Less than 0.2% (typically 0.1%).
- MAXIMUM INPUT COUNTING RATE: 100.000 cps (137-Cs source).
- DYNAMIC RANGE: 20 - 1500 keV.
- HIGH VOLTAGE SUPPLY (OPTIONAL) : Adjustable from 0 to 140V through an external potentiometer (set to 100V when delivered)

2. CONTROLS

FRONT PANEL

- INPUT POLARITY: Toggle switch +/-.
- GATE: Enables output gate.
- COMP.: Enables compensation.
- FINE GAIN: Precision potentiometer for a continuously variable gain factor of X0.5 to X1.5.
- COARSE GAIN: Five-position selector switch selects gain factors of 50, 100, 200, 500 and 1000.
- THRESHOLD: Screwdriver potentiometer to adjust the lower threshold level of the pulse detector.
- THRESHOLD LED: Control the noise level of the system "preamplifier + detector".
- SELECTION: Precision potentiometer to select the maximum risetime.
- COMPENSATION: Precision potentiometer to calibrate the compensation to obtain optimum resolution and peak symmetry.

REAR PANEL

- 110V MAIN POWER FILTRE AND 500mA FUSE (a second fuse is placed in the box)
- BNC INPUT : see section "input"
- PREAMP POWER : is set to 100 V when delivered (required voltage for the most common applications). Adjustable through an external potentiometer (turn clockwise to increase voltage).

3. INPUT

- IN: Type BNC front panel connector. DC-coupled. Accepts signals of a charge sensitive preamplifier, both polarities, rise times in a range from 150 ns to 2500 ns, decay time constants from 0.05 ms to 1 ms; input impedance about 1 KOhm; linear ac maximum 0.5 V; absolute maximum 10 V.

4. OUTPUTS

- OUTPUT ENERGY: Unipolar output of the energy signal. Gated/ungated, type BNC front panel connector, $Z_o = 50 \text{ Ohm}$, short circuit proof, full scale range 0 to + 3 V.
 - PREAMP POWER: 9-pin Amphenol connector, ORTEC standard, provides $\pm 12\text{V}$.

5. ELECTRICAL AND MECHANICAL

- POWER: 110V 60Hz. Power required is +12V at 130mA and -12V at 55mA (without preamplifier).
 - WEIGHT: 1.5 Kg
 - DIMENSIONS: 230 x 220 x 70 mm

INSTALLATION

1. CONNECTION TO POWER

Plug the main power supply cable (furnished) in the 110V / 60 Hz pluger.

2. CONNECTION TO PREAMPLIFIER

The preamplifier output signal is connected to the CPP through the INPUT BNC connector on the front panel. The input impedance is about 1 KOhm and is dc coupled to ground. Therefore, the preamplifier output must be either ac coupled or have approximately zero dc voltage. The internal pole zero cancellation is optimised for a preamplifier decay time constant of 0.05 ms but it will work in a wide range. The pole zero adjustment is very important in order to take full advantage of your CPP. We usually perform the adjustment of the CPP, preamplifier and detector house. In case of trouble, please return us the three items. The detector-preamplifier combination should have a sensitivity of not less than 250mV/MeV.

3. LINEAR OUTPUT CONNECTION

The OUTPUT of the CPP should Be connected to the linear input of the ADC or MCA. The maximum output voltage is 3 V.

THEORY OF OPERATION

The planar detector shape is currently the most commonly produced and applied CdTe detector type. Because of the nearly uniform electrical field inside, both electrons and holes take part in the charge collection. Since the mobility product of the electrons is about ten times bigger than that of holes, the collection time depends largely on the depth of the charge generation. Both charge carriers have nearly the same lifetime. Thus, the charge collection losses are mostly associated with losses of the hole component.

Normally a semiconductor detector is irradiated through the negative electrode. At the surface the absorption of a photon is most probable. The charge is mainly collected by electrons. This shortest collection time is determined by the electron transit time. The maximum in the risetime distribution (Fig. 4) near minimum risetimes corresponds to the interactions near the entry.

Figure 4:

Risetime distribution of the preamplifier pulses.

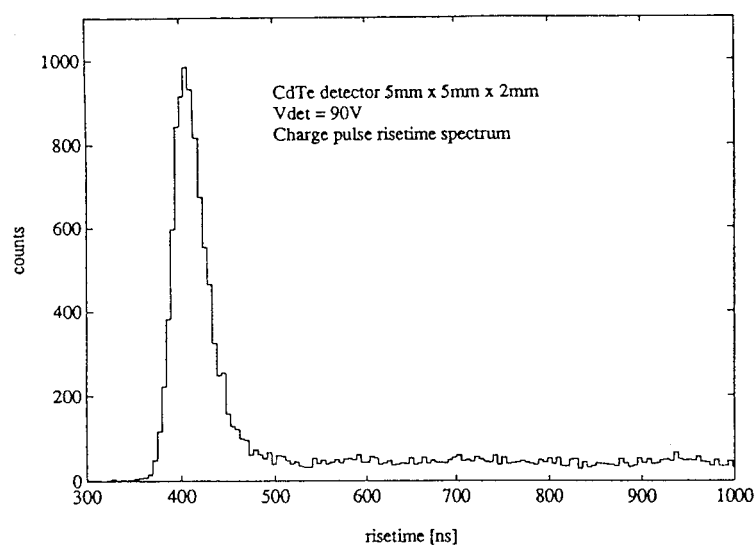

Because of the omit electron collection the recombination losses are small. Events near the

surface with short collection times are registered in the full energy peak.

In the case of deeper interactions the hole fraction of the collection current is more important. Due to the lower hole mobility the overall collection time is longer and therefore the fractional recombination and trapping losses higher. In the spectrum the event is stored in the low energy "tail" of the photopeak.

The channel-position of an event in a spectrum depends not only on the initial photon energy and the type of interaction but also on the depth of the charge generation. Since the electric field inside of the planar detector is nearly uniform, a function of fractional charge loss versus collection time exists. In experiments this function was measured. It is illustrated in Figure 5. This two-dimensional spectrum of a ¹³⁷Cs source was registered using the ungated ENERGY and TIME outputs of the CPP.

Figure 5:

This two-dimensional ¹³⁷Cs spectrum shows clearly the linear displacement of the 662 keV photopeak versus longer charge collection times.

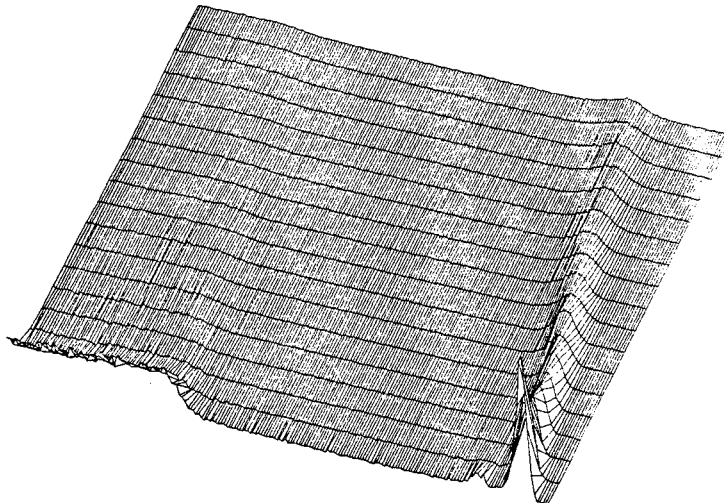

For correction we assume electron collection without any losses. Only hole trapping can be compensated. In case of bad detectors where not only the holes but also the electrons are captured, the compensation fails.

Based on the linear fractional loss versus risetime a compensating circuit has been designed. It multiplies a value proportional to the charge collection time t_{coll} with the height E of the degraded pulse. The result is amplified with a variable gain K (potentiometer COMPENSATION) and added to the voltage of the initial pulse. The corrected output voltage E_{corr} can be calculated as following:

$$E_{corr} = E + K * (t_{coll} * E)$$

It has been found, that this linear relationship is valid in a wide range of risetime and is independent of gamma radiation energy.

CIRCUIT DESCRIPTION

The block diagram is shown in Figure 6. The charge generated in the detector (1) is amplified and converted in the preamplifier (2). After linear amplification (3) and single delay line clipping (4) that use is branched into the spectrometric and compensation/selection path. A gated integrator (13) integrates and stores the energy information. With a constant fraction discriminator (5) a start and a stop pulse are generated on the trailing edge of the clipped pulse. The time between these two signals is converted into a voltage by means of the time amplitude converter TAC (6). This voltage is linearly proportional to the decay time of the shaped pulse and thus to the charge collection time of the detector (1).

In a single channel analyser (7) the output voltage of the TAC (6) is compared with a voltage window which represents a minimum (8) and maximum (9) risetime. The result controls the output gates (15).

At the summation point (10) from the TAC output an adjustable voltage (8) is subtracted. It represents the minimum charge collection time t_{zero} for events near the negative electrode of the planar CdTe detector (1).

In the analogue multiplier (11) the difference voltage is multiplied with the output voltage of the gated integrator (13). The compensated signal is applied at the OUTPUT of the energy signal (16).

Figure 6 :
Block schematic of the Charge Loss Corrector

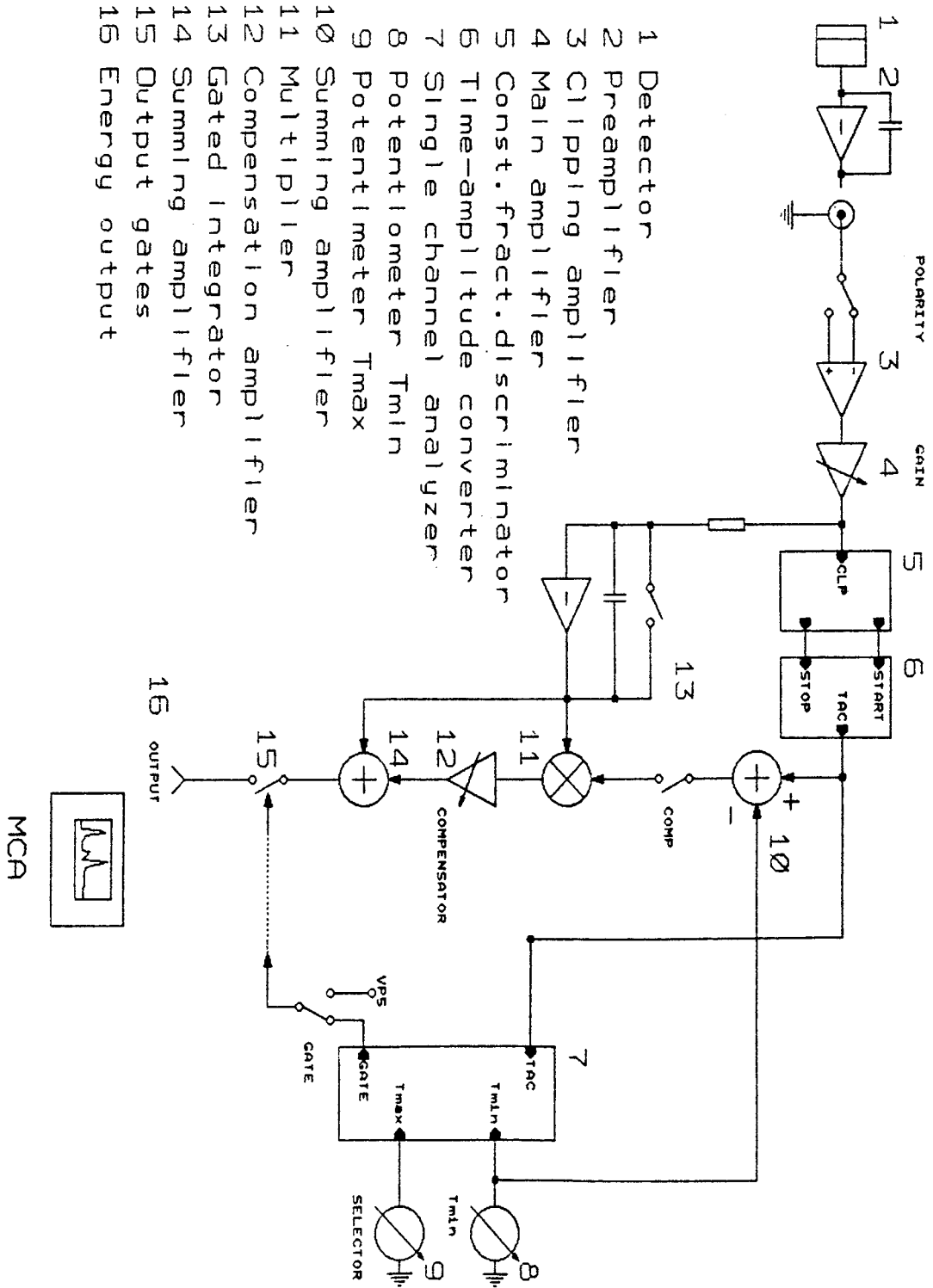

HOW TO USE YOUR CPP II

1. INSTALLATION

For the first use of your CPP you should begin by testing the device with a pulse generator.

You should proceed as follow:

1. Connect the main power supply cable to the rear panel of the CPP and plug it in the 110V pluger.
2. The potentiometer Threshold should be turned full counterclockwise.
3. Put the CPP into operation. The Threshold Led should be constantly ON.
Set the functions as follow:
 - COARSE GAIN: 50
 - FINE GAIN: 5.0
 - THRESHOLD: Turn the screwdriver potentiometer full counterclockwise.
 - COMPENSATOR: 0
 - SELECTOR: 10.0
 - GATE: Disable (lower switch position).
 - COMP: Disable (lower switch position).
4. Connect the output of the CPP to an oscilloscope.
5. Turn the threshold clockwise in order to obtain a stable signal.
6. You should see on the oscilloscope a 1 μ s square wave signal.

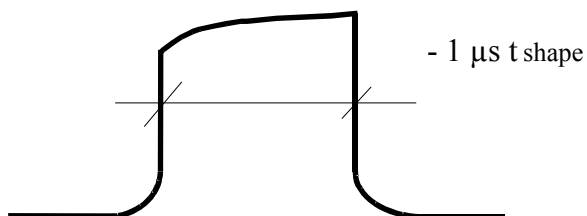

7. Adjust the FINE GAIN in order to obtain an amplitude of 2 volts.

8. In order to test the COMPENSATOR functions proceed as follow:

- COMP: Enable (upper switch position).
- GATE: Disable (lower switch position).
- COMPENSATOR: Full counterclockwise to position 0.

Turn the 10 turn COMPENSATOR potentiometer (from 0 to 10) and observe the amplitude of the signal which should increase.

9. The internal risetime SELECTOR can be tested as follow:

- GATE: Enable (upper switch position).
- COMP: Disable (lower switch position).
- SELECTOR: full clockwise to position 10.0

Turn the selector potentiometer counterclockwise. At position 0 no output signal should be measured.

In situation where the CPP is suspected of a dysfunction, please return it to EURORAD's facility.

2. TEST WITH A RADIATION SOURCE

You can now test your CPP with a detector and a radiation source.

As a first step, you should check if your detector can be used with the CPP.

HOW TO CHECK THE COMPATIBILITY BETWEEN YOUR DETECTOR AND THE CPP

Introduction : the device performs a linear compensation of trapping losses by calculating a correction term from the collection time of a charge pulse and its height. This function can be described as follow:

$$V_{out} = V_{in} (1 + K \cdot t_r)$$

where

V_{out} = corrected pulse height

V_{in} = initial pulse height

K = correction factor.

The correction factor K depends on the applied bias voltage and is a detector property. Normally, in the CPP II model, you can adjust the Compensation with a 10 turn potentiometer (in the CPP I model you had to add a resistance in order to adapt the detector).

Detector's test : this test is performed by using a gaussian amplifier.

1. Connect the detector to the preamplifier.
2. Connect the preamplifier to a normal gaussian amplifier (ORTEC 571 or similar).
3. Apply to your planar CdTe detector the nominal bias voltage. The shaping time should be $1\mu\text{s}$.
4. Use a gamma ray energy above 100 keV.
5. Connect your gaussian amplifier to an oscilloscope and observe a certain number of "long pulses". This is encouraging.

Figure 7:

"Long" pulses at the output of a gaussian amplifier.

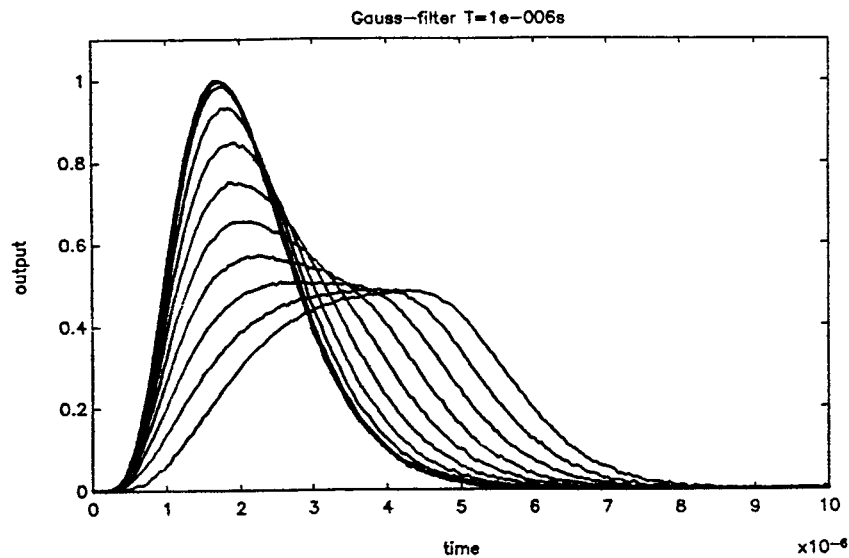

OPERATION MODE

Installation and pole zero (in case you have a test input on your preamplifier, otherwise go to section Installation) :

1. Connect the detector to the preamplifier.
2. Connect the Amphenol DB9 preamplifier to the CPP.
3. To check the pole zero of your preamplifier connect a square wave generator to the test input of the preamplifier and connect the output of the preamplifier to an oscilloscope. The signal should return to the base line.

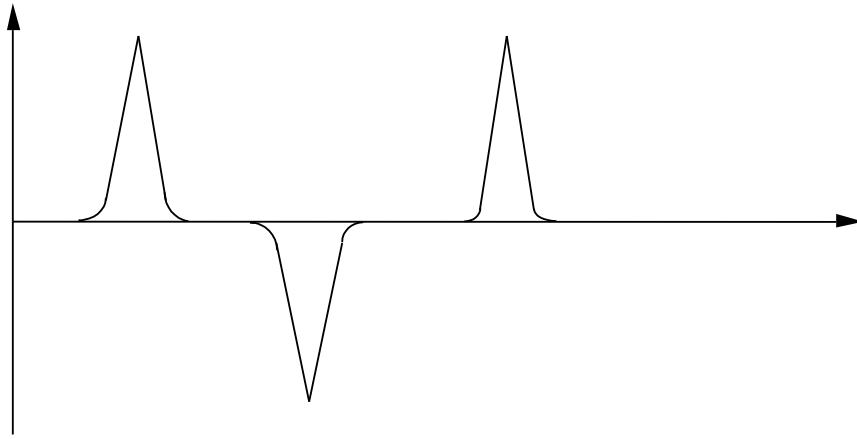

Threshold adjustment :

1. Connect the preamplifier output to the CPP input.
2. Apply the nominal bias voltage to the detector and wait a few seconds until the high voltage on the detector gets stabilised.
3. Connect the CPP output to an oscilloscope and MCA.
4. The CPP's functions should be set as follow before use:
 - Threshold screwdriver: Full counterclockwise.
 - Threshold Led: ON
 - COMPENSATOR: Full counterclockwise, position 0.
 - SELECTOR: Full clockwise, position 10.
 - GATE: Disable (lower switch position).
 - COMP: Disable (lower switch position).
 - COARSE: 50
 - FINE: 5.0
 - POLARITY: Will depend on the preamplifier output pulses:
 - upper switch position = negative polarity
 - lower switch position = positive polarity.
5. Adjust the threshold screwdriver in order to obtain intermittent flashes of the red Led.
6. Place a 137-Cs source on the top of the detector. The red Led will be continually bright (ON).
7. Adjust the output signal to 2 volts with COARSE and FINE GAIN.
8. Adjust the threshold as low as possible.

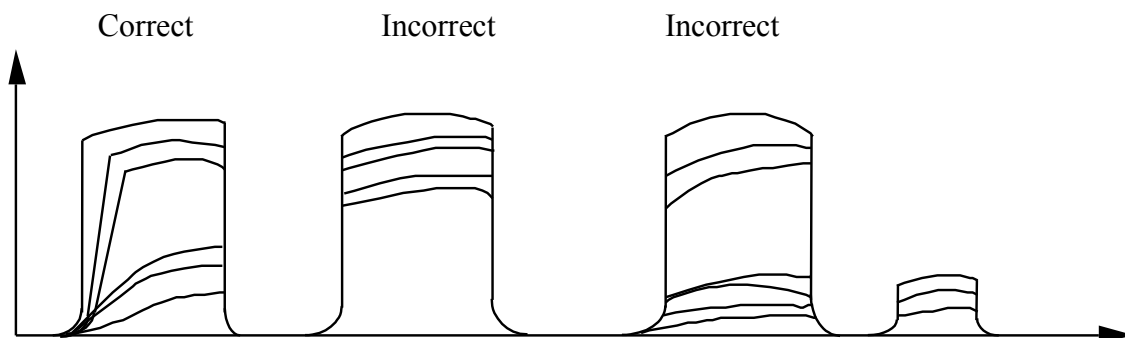

Operation in compensation mode :

Set the functions as follow:

- GATE: Disable
- SELECTOR: Position 10.0
- COMP: Enable (upper switch position).
- COMPENSATOR: Full counterclockwise, position 0.

In the compensation mode a correction circuit transfers pulses from the low energy "tail" into the photopeak. This operation enhances the energy resolution and photopeak efficiency. It enables high resolution spectrometry with CdTe and HgI₂ detectors and shortens the measuring time.

In order to optimise the photopeak shape you should use the compensation mode without SELECTOR (GATE disable).

Turn the COMPENSATOR potentiometer clockwise and observe the signal on the oscilloscope.

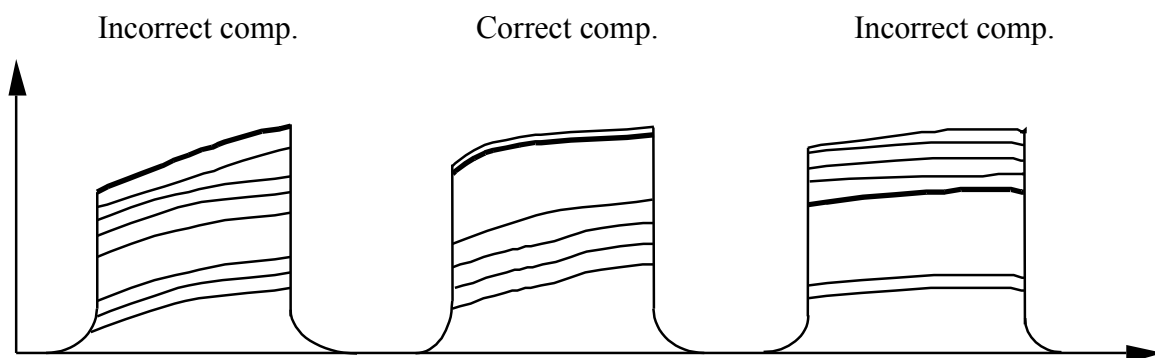

On your MCA you can get different spectra (see Figures 8,9,10 and 11).

Figure 8:

Initial 137-Cs spectrum: COMP: Disable, GATE: Disable

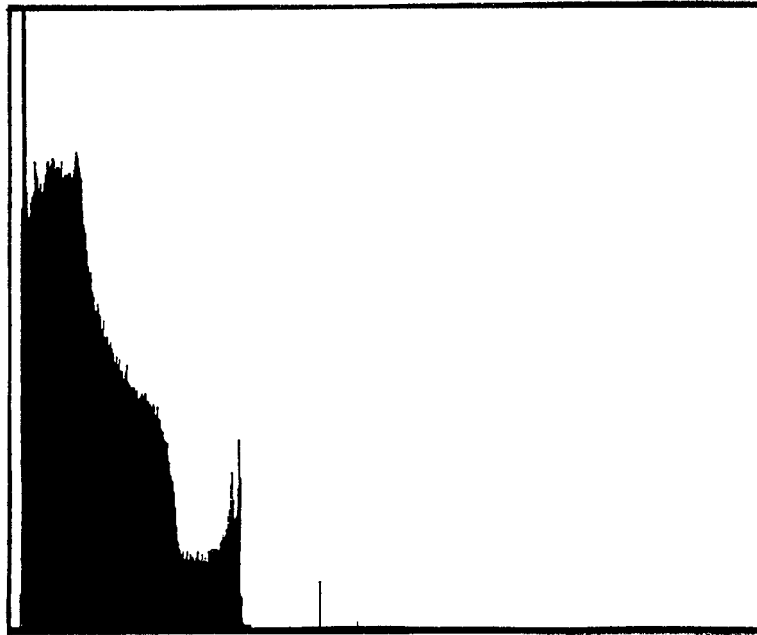

Figure 9:

Undercompensated 137-Cs spectrum, increase COMPENSATION

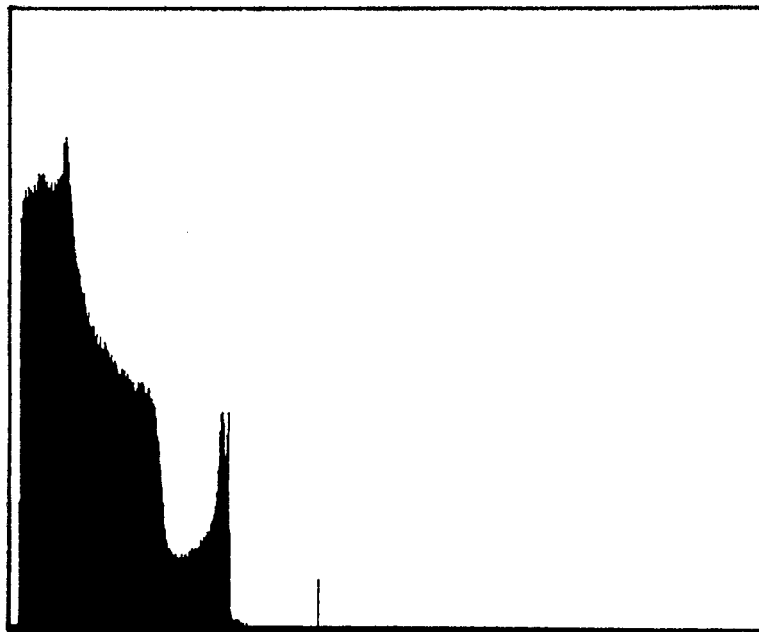

Figure 10:

137-Cs spectrum with optimum compensation adjustment



Figure 11:

Overcompensated 137-Cs spectrum. decrease COMPENSATION

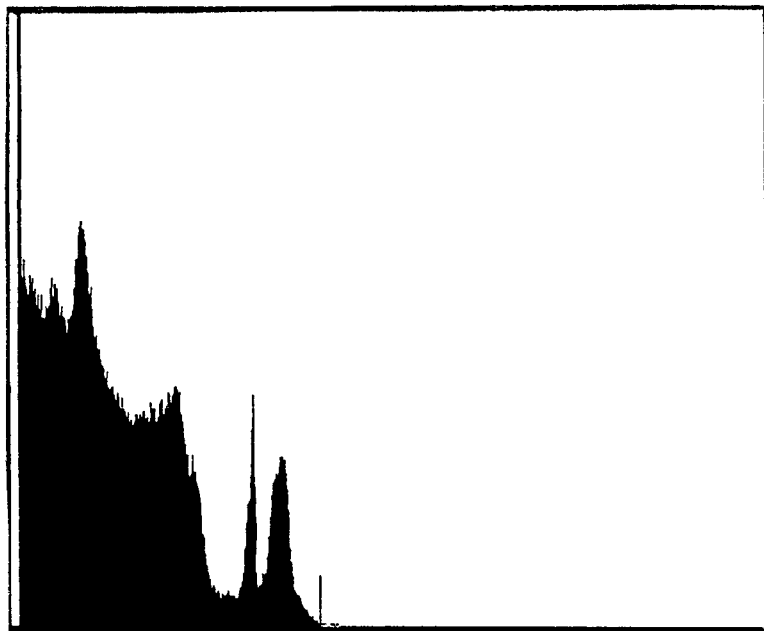

Operation in selection mode :

In this operation mode you can obtain better energy resolution but the appreciable loss of detection efficiency limits its application. It should be used in case of high radiation source activities or if there are no restrictions for measuring time.

In order to select the risetime proceed as follow:

- COMP: Enable (upper switch position).
- COMPENSATOR: Position where you get the optimum ¹³⁷Cs spectrum.
- GATE: Enable (upper switch position).
- SELECTOR: Full clockwise, position 10.

To exclude pulses with long risetimes and therefore to enhance the energy resolution turn the SELECTOR potentiometer counterclockwise and observe the signal obtained on the oscilloscope.

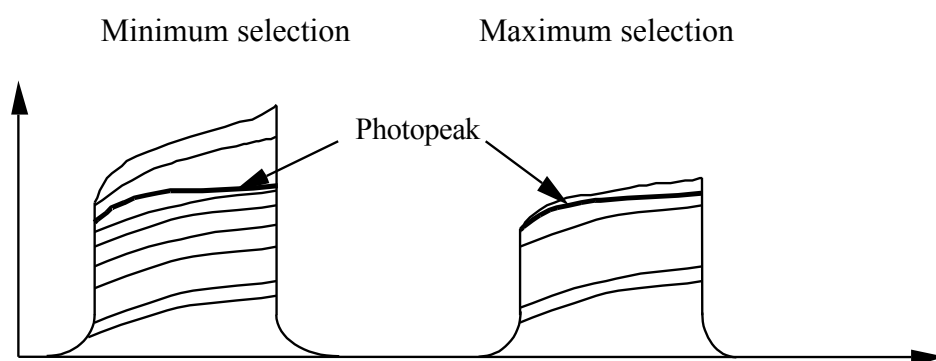

The spectrum of the Figure 12 shows the maximum and the minimum selection you can have.

Figure 12:

Comparison of two ¹³⁷Cs spectra
 Left: SELECTOR = 10, Right: SELECTOR = 3.1

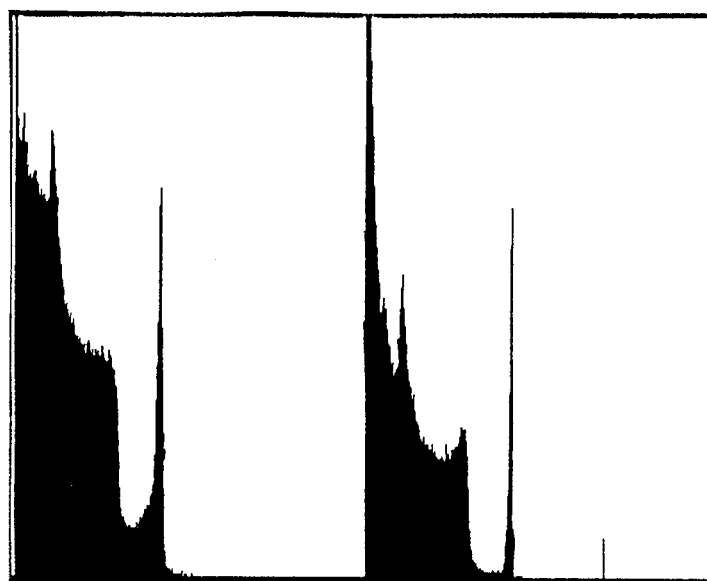

Resolution / efficiency optimisation :

The pulse preselection influences basically the efficiency and the energy resolution. The smaller the risetime window the better the resolution but the higher the efficiency loss.

As an example, the Figure 13 illustrates this relation between the efficiency and the energy resolution.

Figure 13:

^{133}Ba spectra measured with CPP and different preselection (solid line) in comparison with the initial spectrum (dotted line).

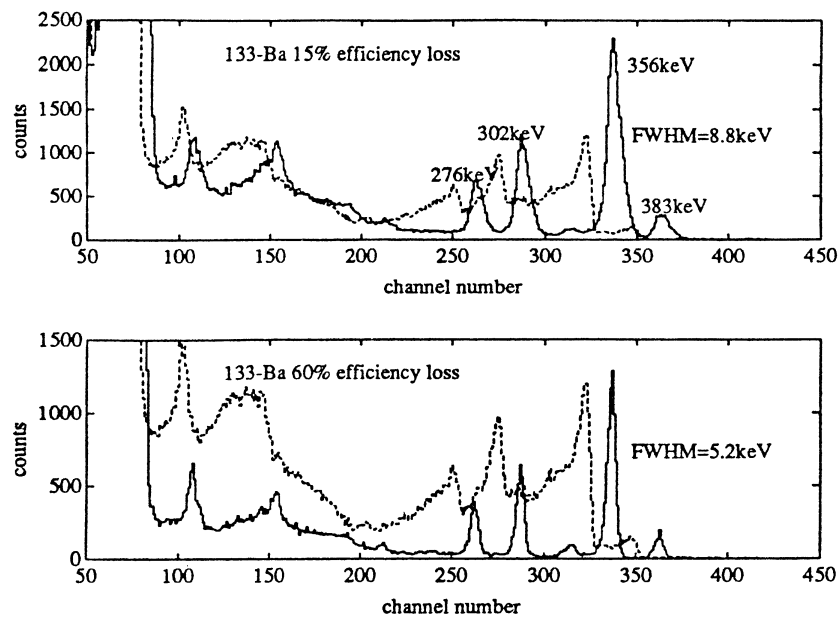
**HOW TO OBTAIN BETTER PERFORMANCES**

You must be aware that all CdTe detectors are not compatible with the CPP since they have to present a certain number of characteristics as developed in section 6.2.

All EURORAD detectors are tested with the CPP and we can therefore assure you that they can be used with the CPP.

However, in case of troubles, questions or suggestions do not hesitate to contact us.